

Load Cell for Elevators

FEATURES

- Used in elevators for safety, traffic control and energy control
- Low profile
- Amplified output (0.4–12.4 VDC)
- Located under the inner cage

DESCRIPTION

The Model 250 is a low-profile, pancake-type load cell, especially designed for use in elevators. Model 250 is equipped with a built-in amplifier and is commonly placed between the inner and outer cages of the elevators cabin. The number of load cells required depends upon the cabin size and ranges from two to eight load cells (some may be dummies).

Model 250 is used for 3 reasons:

1. **Safety**—The load cell is an overload sensor, that indicates when the weight in the elevator passes a certain value that was set by the elevator designers. It also can be used to prevent a child from using the elevator; for example, the elevator control system can prevent movement if a demand from a low-weight user (a child) is made.
2. **Traffic Control**—The load cell is a sensor that transmits load information to the elevator control system, used in buildings with more than one elevator.



This information can be used to decide which elevator to send to a user, taking into account the load in the elevator, in order to shorten waiting time or prevent full/semi full elevators from stopping.

3. **Energy Saving**—The load cell is a sensor that transmits load information to the elevator control system, used in buildings with more than one elevator. This information is used in energy saving algorithms of the control system.

A common elevator is constructed from an external cage with an internal cabin. The cabin is positioned on several rubber dampers, according to its size. Load cells (or dummies) are located between these dampers and the cabin (under the cabin). The number of load cells depends on the design.

OUTLINE DIMENSIONS in millimeters

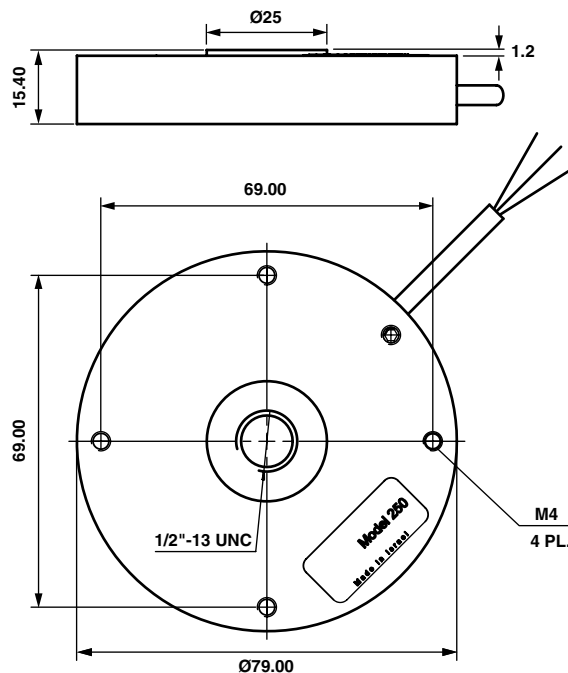

Load Cell for Elevators

SPECIFICATIONS		
PARAMETER	VALUE	UNIT
Rated capacity—R.C.	500	kg
Rated output—R.O.	24	mV/kg
Rated output tolerance	0.24	±mV/kg
Zero balance	0–0.5	V
Total error	5	±% of R.O.
Temperature range, safe	–30 to +70	°C
Maximum safe static overload	200*	% of R.C.
Ultimate static overload	300	% of R.C.
Excitation, recommended	24	VDC regulated
Excitation, minimum	8	VDC
Excitation, maximum	28	VDC
Current consumption	30	mA
Insulation resistance	>2000	MΩ
Construction	Alloy steel yellow zinc plated	
Environmental protection	IP65	
Color code	Red: +Exc, Black: Com, White: Out	
Cable length	5	m

* Amplifier is saturated at 500 kg

All specifications subject to change without notice.